

Features

- 32-bit PCI-Bus, Plug and Play
- Multi-I/O port configurations includes 16 DI & 16 DO, 32 DI or 32 DO
- Up to 80M Bytes/sec data transfer rate
- Bus-mastering data transfer with scatter gather technology
- On-board internal timer pacer trigger
- On board two 16k words FIFO for DI and DO channels,
- Multi-configurations for digital waveform generator
- ACK and REQ for handshaking data transfer
- Multiple interrupt sources are programmable
- Compact, half-size PCB
- Rugged 100-pin SCSI-II connector
- Active terminators for high speed and long distance data transfer

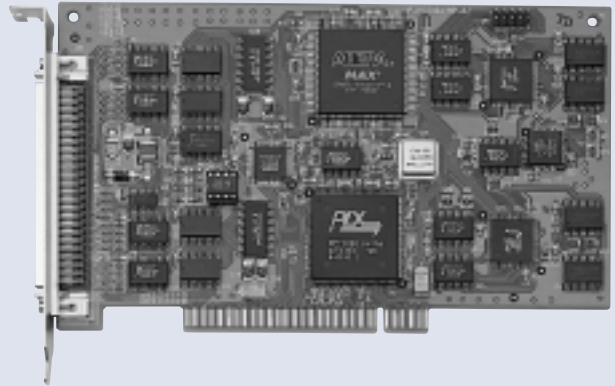

Introduction

The PCI-7300A is PCI form factor, ultra-high speed digital I/O card. It consists of 32 digital input and/or output channel. High performance designs and state-of-the-art technology make this card ideal for high-speed digital input and output applications. The block diagram is shown in next page.

Maximum Data Acquisition Rate

The maximum data transfer rates between external device and on board FIFO can be up to 80MB/s for DO and 160MB/s for DI. 80MB/s is achieved by 32-bit bus width multiplied by internal 20MHz clock. 160MB/s is achieved by 32-bit bus width with external 40MHz clock for digital input channels only. The PCI-7300A can reach this high speed when the acquired data length is less than FIFO size (16 K samples).

Bus Mastering DMA

The PCI-7300A performs high-speed data transfers between on-board FIFO and host memory using bus mastering DMA and scatter gather via a 32-bit PCI bus architecture. PCI bus greatly extends data throughput up to 132M bytes/sec (burst) and also has provisions for processor-free DMA. When the PCI-7300A becomes the bus master, it takes control of the PCI bus, transfers data at burst speed, then releases the bus for other peripheral use. User can utilize the unlimited host memory to store data when the data acquisition bandwidth is less then the sustained PCI bus bandwidth.

Supporting Scatter Gather

For bus master devices, the hardware has some sort of built-in support for transferring data to and from noncontiguous ranges of physical memory. The PCI-7300A contains multiple pairs of address and length registers, each one describing a single contiguous buffer segment. This allows PCI-7300A to perform I/O using buffers that are scattered throughout DMA address space. These multiple address and count registers are often referred to as a **scatter/gather list**, but you can also think of these bus masters as having their own built-in mapping registers.

I/O Port Configurations

The PCI-7300A is configured as two ports, PORTA and PORTB. Each port controls 16 digital I/O lines. The I/O can configure as either input or output. According to outside device environment, users can configure PCI-7300A to meet all high-speed digital I/O data transferring. PCI-7300A can support many different digital I/O operation modes:

Internal Clock: the digital input and output operations are handled by internal clock and data is transferred by bus mastering DMA.

External Trigger: the digital input and output operations are handled by external In / Out strobe signals (DI_REQ or DO_ACK) and data is transferred by bus mastering DMA.

Handshaking: through REQ and ACK signals, the digital I/O data can have simple handshaking data transfer.

Pattern Generation: reading or writing digital data at a predetermined rate. Users can control this rate internally by on-board counters with 50ns timing resolution.

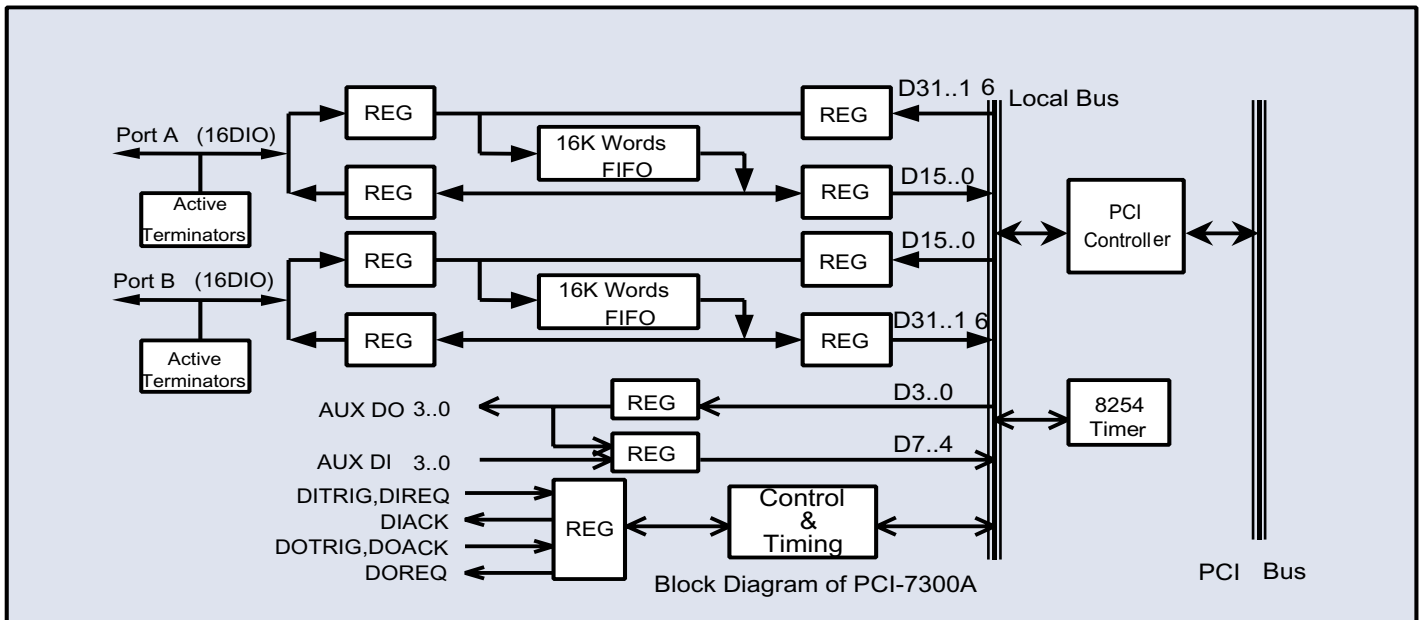

Specifications

Digital I/O (DIO)

- Number of channels: 32
- Device: IDT 74FCT373
- I/O configurations:
 - 16 DI & 16 DO
 - 32 DO
 - 32 DI
- I/O signal characteristic:
 - Terminator off: TTL compatible
 - Low: +0.5V @ +/- 20mA
 - High: +2.7V @ +/- 1 mA(max)
 - Terminator on:
 - Termination resistor: 110 Ohms
 - Termination voltage: 2.9V
 - Low: +0.5V @ +/- 22.4 mA
 - High: +2.7V @ +/- 1 mA(max)
- Data transfers: Bus master DMA with Scatter-Gather
- Data transfer bus width: 32/16/8 bits (programmable)
- Max transfer rate:
 - DO: 80M Bytes/s, 32-bit output @ 20MHz
 - DI: 80M Bytes/s, 32-bit input @ 20MHz

Auxiliary Digital I/O

- Number of channels: 4 DI, 4 DO
- TTL Compatible
- Passive terminators for 4 DIN (220 Ω pull high, 330Ω pull low)
- Data transfer mode: PIO

Programmable Timer

- Device: 82C54-10
- Digital input pacer: 20MHz, 10MHz or clock output of Timer #0
- Digital output pacer: 20MHz, 10MHz or clock output of Timer #1
- General purpose timer: output of Timer #2

General Specifications

- Connector: 100-pin SCSI-II
- Operating temperature: 0° ~ 60°C
- Storage temperature: -20° ~ 80°C
- Humidity: 5 ~ 90%, non-condensing
- Power requirement: +5V @ 830mA maximum
- Dimension: 179 mm x 102 mm

Termination Boards

- DIN-100S • DIN-502S

Ordering Information

PCI-7300A

80MB/S Ultra-high speed DIO card

PCI-7300A/D

PCI-7300A with DIN-100S

Note: The above products are shipped with software development kit for DOS/Win-95/98/NT/2000, PCIS-LVIEW and PCIS-VEE.

Pin Assignments of 100-pin SCSI-type Connector

GND	1	51	PB15
GND	2	52	PB14
GND	3	53	PB13
GND	4	54	PB12
GND	5	55	PB11
GND	6	56	PB10
GND	7	57	PB9
GND	8	58	PB8
GND	9	59	PB7
GND	10	60	PB6
GND	11	61	PB5
GND	12	62	PB4
GND	13	63	PB3
GND	14	64	PB2
GND	15	65	PB1
GND	16	66	PB0
GND	17	67	DO_ACK
GND	18	68	DO_REQ
GND	19	69	DO_TRG
GND	20	70	AUXO3
GND	21	71	AUXO2
GND	22	72	AUXO1
GND	23	73	AUXO0
GND	24	74	TERMPWR
GND	25	75	TERMPWR
GND	26	76	TERMPWR
GND	27	77	TERMPWR
GND	28	78	AUXI3
GND	29	79	AUXI2
GND	30	80	AUXI1
GND	31	81	AUXI0
GND	32	82	DI_ACK
GND	33	83	DI_REQ
GND	34	84	DI_TRG
GND	35	85	PA15
GND	36	86	PA14
GND	37	87	PA13
GND	38	88	PA12
GND	39	89	PA11
GND	40	90	PA10
GND	41	91	PA9
GND	42	92	PA8
GND	43	93	PA7
GND	44	94	PA6
GND	45	95	PA5
GND	46	96	PA4
GND	47	97	PA3
GND	48	98	PA2
GND	49	99	PA1
GND	50	100	PA0